



- Per soluzioni su Misura
- Per bocche di lupo in cemento

Il grigliato **elettrosaldato** rappresenta la linea classica di produzione.

E' composto dalla giunzione ortogonale tramite elettrosaldatura di piatti e collegamenti in quadri ritorti oppure in tondi lisci. Ad ogni incrocio piatti e collegamenti risultano quindi fusi ed elettrosaldati tra loro, per cui il prodotto ottenuto possiede caratteristiche di particolare resistenza e compattezza.

La vasta gamma di maglie abbinata ai vari tipi di piatto permette al grigliato di essere utilizzato quale piano di calpestio portante oppure come protezione verticale per recinzioni, parapetti ed inferriate.



# Maglia mm 15x76

PIATTO PORTANTE mm	COLLEGAMENTO mm	PESO GREZZO kg/mq	PESO ZINCATO kg/mq	DIMENSIONI GRATA
<u>20x2</u>	4	22,36	24,01	6100x999
<u>25x2</u>	5	28,91	30,97	6100x999
<u>25x3</u>	5	42,04	44,17	6100x1000
<u>30x2</u>	5	34,18	36,59	6100x999
<u>30x3</u>	5	49,93	52,41	6100x1000
<u>40x2</u>	5	44,71	47,84	6100x999
<u>40x3</u>	5	65,71	68,91	6100x1000
<u>50x3</u>	5	81,50	85,40	6100x1000
<u>50x4</u>	5	107,98	111,97	6100x1000
<u>60x4</u>	5	129,07	133,76	6100x1000
<u>70x4</u>	5	150,15	155,55	6100x1000
Prodotti speciali superantisdrucchiolo:				
<u>30x3</u>	5	48,30	50,81	6100x1000



# Maglia mm 22x38

PIATTO PORTANTE mm	COLLEGAMENTO mm	PESO GREZZO kg/mq	PESO ZINCATO kg/mq	DIMENSIONI GRATA
<u>25x2</u>	4,5	22,29	23,86	6100x997
<u>25x3</u>	5	32,30	33,95	6100x998
<u>30x3</u>	4,5	36,75	38,62	6100x998



# Maglia mm 22x76

PIATTO PORTANTE mm	COLLEGAMENTO mm	PESO GREZZO kg/mq	PESO ZINCATO kg/mq	DIMENSIONI GRATA
<u>25x2</u>	4,5	20,20	21,65	6100x997
<u>25x3</u>	5	29,73	31,23	6100x998
<u>30x2</u>	4,5	23,83	25,52	6100x997
<u>30x3</u>	4,5	34,67	36,4	6100x998
<u>30x4</u>	6	47,30	49,14	6100x994
<u>40x3</u>	5	46,21	48,46	6100x993
<u>40x4</u>	6	61,83	64,16	6100x994
<u>50x4</u>	6	76,36	79,18	6100x994
<u>60x4</u>	6	90,90	94,20	6100x994
<u>70x4</u>	6	105,43	109,22	6100x994
Prodotti speciali superantisdrucchiolo:				
<u>30x3</u>	4,5	34,39	36,17	6100x998



# Maglia mm 25x25

PIATTO PORTANTE mm	COLLEGAMENTO mm	PESO GREZZO kg/mq	PESO ZINCATO kg/mq	DIMENSIONI GRATA
<b>20x2</b>	4	16,79	18,01	6100x1000
<b>25x2</b>	4	20,01	21,44	6100x1002
<b>30x3</b>	5	35,05	36,81	6100x1003



# Maglia mm 25x50

PIATTO PORTANTE mm	COLLEGAMENTO mm	PESO GREZZO kg/mq	PESO ZINCATO kg/mq	DIMENSIONI GRATA
<b>20x3</b>	4,5	27,20	28,60	6100x1005



# Maglia mm 25x76

PIATTO PORTANTE mm	COLLEGAMENTO mm	PESO GREZZO kg/mq	PESO ZINCATO kg/mq	DIMENSIONI GRATA
<b>25x2</b>	4	17,35	18,61	6100x1002
<b>25x3</b>	4,5	26,15	27,49	6100x1003
<b>30x2</b>	4	20,57	22,04	6100x1002
<b>30x3</b>	4,5	30,97	32,52	6100x1003
<b>40x3</b>	5	41,08	43,08	6100x1003
<b>50x4</b>	6	67,82	70,33	6100x1004
<b>60x4</b>	6	80,64	83,58	6100x1004
<b>70x4</b>	6	93,47	96,84	6100x1004
<b>Prodotti speciali superantisdrucchio:</b>				
<b>40x3</b>	5	39,40	41,40	6100x1003

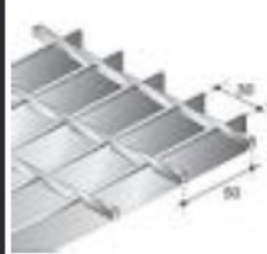

# Maglia mm 30x50

PIATTO PORTANTE mm	COLLEGAMENTO mm	PESO GREZZO kg/mq	PESO ZINCATO kg/mq	DIMENSIONI GRATA
<b>25x3</b>	4,5	23,19	24,39	6100x998
<b>30x3</b>	4,5	27,20	28,58	6100x998
<b>40x3</b>	4,5	35,22	36,96	6100x998
<b>40x4</b>	6	48,52	50,37	6100x994
<b>Prodotti speciali superantisdrucchio:</b>				
<b>30x4</b>	6	35,90	37,39	6100x994



# Maglia mm 30x100

PIATTO PORTANTE mm	COLLEGAMENTO mm	PESO GREZZO kg/mq	PESO ZINCATO kg/mq	DIMENSIONI GRATA
<u>25x3</u>	4,5	21,62	22,73	6100x998
<u>25x5</u>	6	36,31	37,52	5850x995
<u>30x3</u>	4,5	25,63	26,92	6100x998
<u>30x5</u>	6	43,02	44,41	5850x995
<u>40x4</u>	6	45,74	47,46	6100x994
<u>50x4</u>	6	56,48	58,57	6100x994
<b>Prodotti speciali superantisdrucchiolo:</b>				
<u>25x5</u>	6	33,96	35,18	5850x995
<u>30x3</u>	5	24,71	26,01	6100x993
<u>30x5</u>	6	40,67	42,06	5850x995



# Maglia mm 34x38

PIATTO PORTANTE mm	COLLEGAMENTO mm	PESO GREZZO kg/mq	PESO ZINCATO kg/mq	DIMENSIONI GRATA
<u>25x2</u>	4,5	15,99	17,10	6100x997
<u>25x3</u>	4,5	21,88	23,02	6100x997
<u>30x2</u>	4,5	18,35	19,62	6100x997
<u>30x3</u>	4,5	25,42	26,72	6100x998
<u>40x3</u>	4,5	32,50	34,12	6100x998
<u>40x4</u>	5	43,21	44,90	6100x990
<b>Prodotti speciali superantisdrucchiolo:</b>				
<u>30x3</u>	4,5	24,18	25,48	6100x998



# Maglia mm 34x76

PIATTO PORTANTE mm	COLLEGAMENTO mm	PESO GREZZO kg/mq	PESO ZINCATO kg/mq	DIMENSIONI GRATA
<u>25x2</u>	4,5	13,90	14,89	6100x997
<u>25x3</u>	4,5	19,79	20,81	6100x998
<u>30x2</u>	4,5	16,26	17,41	6100x997
<u>30x3</u>	4,5	23,33	24,51	6100x998
<u>40x3</u>	4,5	30,41	31,91	6100x998
<u>40x4</u>	5	40,64	42,19	6100x990
<u>50x4</u>	6	51,28	53,19	6100x990
<u>60x4</u>	6	60,80	63,02	6100x990
<u>70x4</u>	6	70,31	72,86	6100x990



# Maglia mm 43x44

PIATTO PORTANTE mm	COLLEGAMENTO mm	PESO GREZZO kg/mq	PESO ZINCATO kg/mq	DIMENSIONI GRATA
<u>25x2</u>	5	12,83	13,70	6100x1894



# Maglia mm 63x66

PIATTO PORTANTE mm	COLLEGAMENTO mm	PESO GREZZO kg/mq	PESO ZINCATO kg/mq	DIMENSIONI GRATA
<u>25x2</u>	5	8,77	9,36	6100x1892
<u>25x3</u>	5	12,05	12,67	6100x1515
<u>25x3</u>	5	11,98	12,59	6100x1893



# Maglia mm 63x132

PIATTO PORTANTE mm	COLLEGAMENTO mm	PESO GREZZO kg/mq	PESO ZINCATO kg/mq	DIMENSIONI GRATA
<u>25x2</u>	5	7,65	8,18	6100x1514
<u>25x2</u>	5	7,60	8,13	6100x1892
<u>25x3</u>	5	10,88	11,44	6100x1515
<u>25x3</u>	5	10,81	11,36	6100x1893
<u>30x4</u>	6	17,10	17,77	6100x1894



# Maglia mm 126x132

PIATTO PORTANTE mm	COLLEGAMENTO mm	PESO GREZZO kg/mq	PESO ZINCATO kg/mq	DIMENSIONI GRATA
<u>25x3</u>	5	6,22	6,54	6100x1515
<u>25x3</u>	5	6,14	6,46	6100x1893

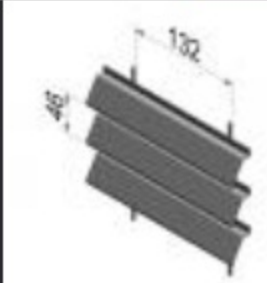

# Maglia mm 46x132 WING

PIATTO PORTANTE mm	COLLEGAMENTO mm	PESO GREZZO kg/mq	PESO ZINCATO kg/mq	DIMENSIONI GRATA
<u>47x1.5</u>	4	14,45	15,75	6100x1584



# Maglia mm 34x100 OFF-

Il grigliato OFF-SHORE trova particolare ed esclusiva applicazione nella costruzione delle piattaforme marine. Costituito da piatti dentellati alternati a tondi, allo scopo di alleggerire il pannello, mantiene intatte ed inalterate le caratteristiche di sicurezza. Grazie alla struttura con maglie fitte, acquisisce inoltre la capacità di trattenere corpi di piccole dimensioni ( $\geq 15$  mm), condizione fondamentale per gli impianti off-shore.

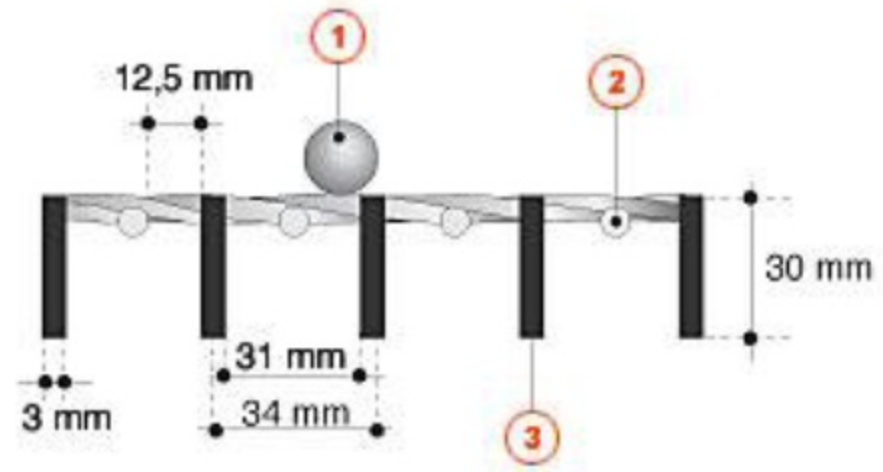
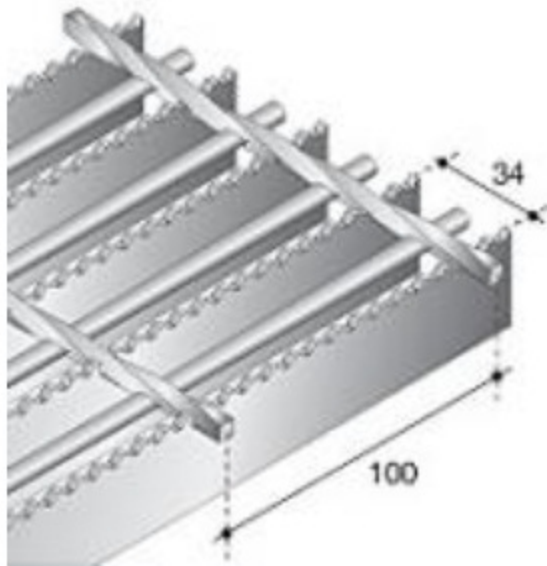

## Prodotti speciali superantisdrucchiolo:

PIATTO PORTANTE mm	COLLEGAMENTO mm	PESO GREZZO kg/mq	PESO ZINCATO kg/mq	DIMENSIONI GRATA
<b>30x3</b>	6	29,27	30,67	6100x998